

4

3

2

1

ITEM NO.	PART NUMBER	Material	QTY.
1	L2x2x0.25x30	ANGLE 2X2X1/4 - 30" LONG	2
2	L2x2x0.25x16	ANGLE, 2X2X1/4 - 16" LONG	4
3	side frame	FLAT BAR 3/8 X 2	2
4	mounting tab	FLAT BAR 1/4 X 1 1/2	4
5	HBOLT 0.5000-20x3x1.25-N		4
6	HBOLT 0.5000-20x1.5x1.25-N		2
7	HNUT 0.5000-20-D-N		2

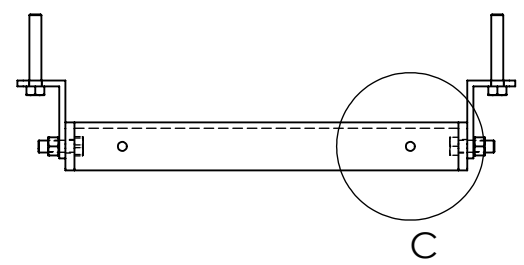

C

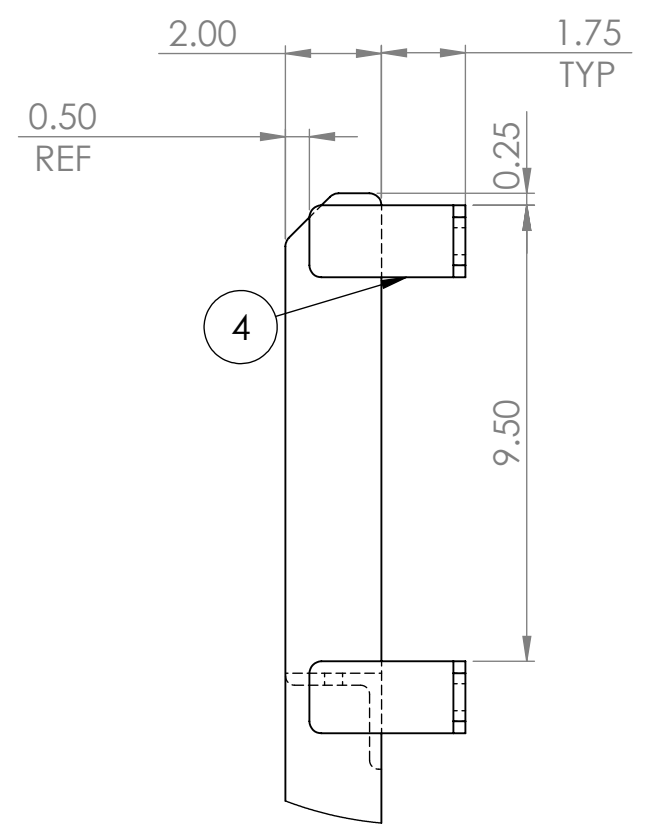
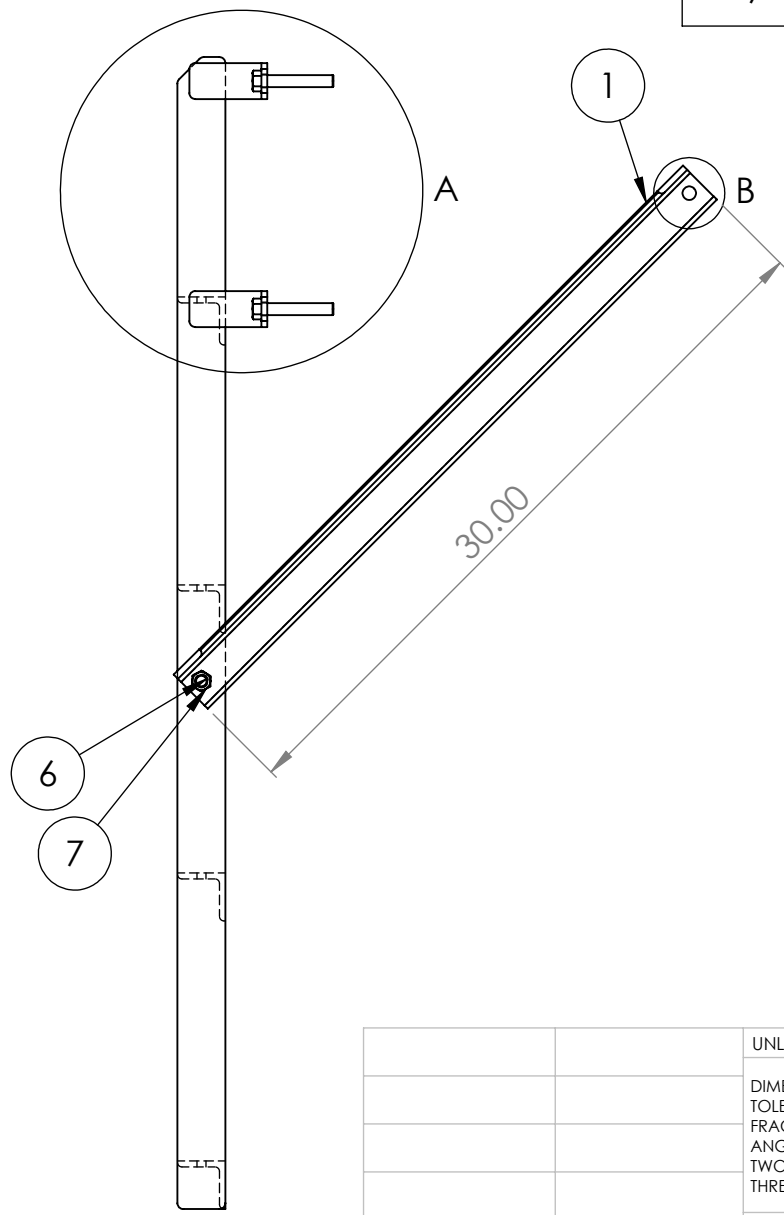
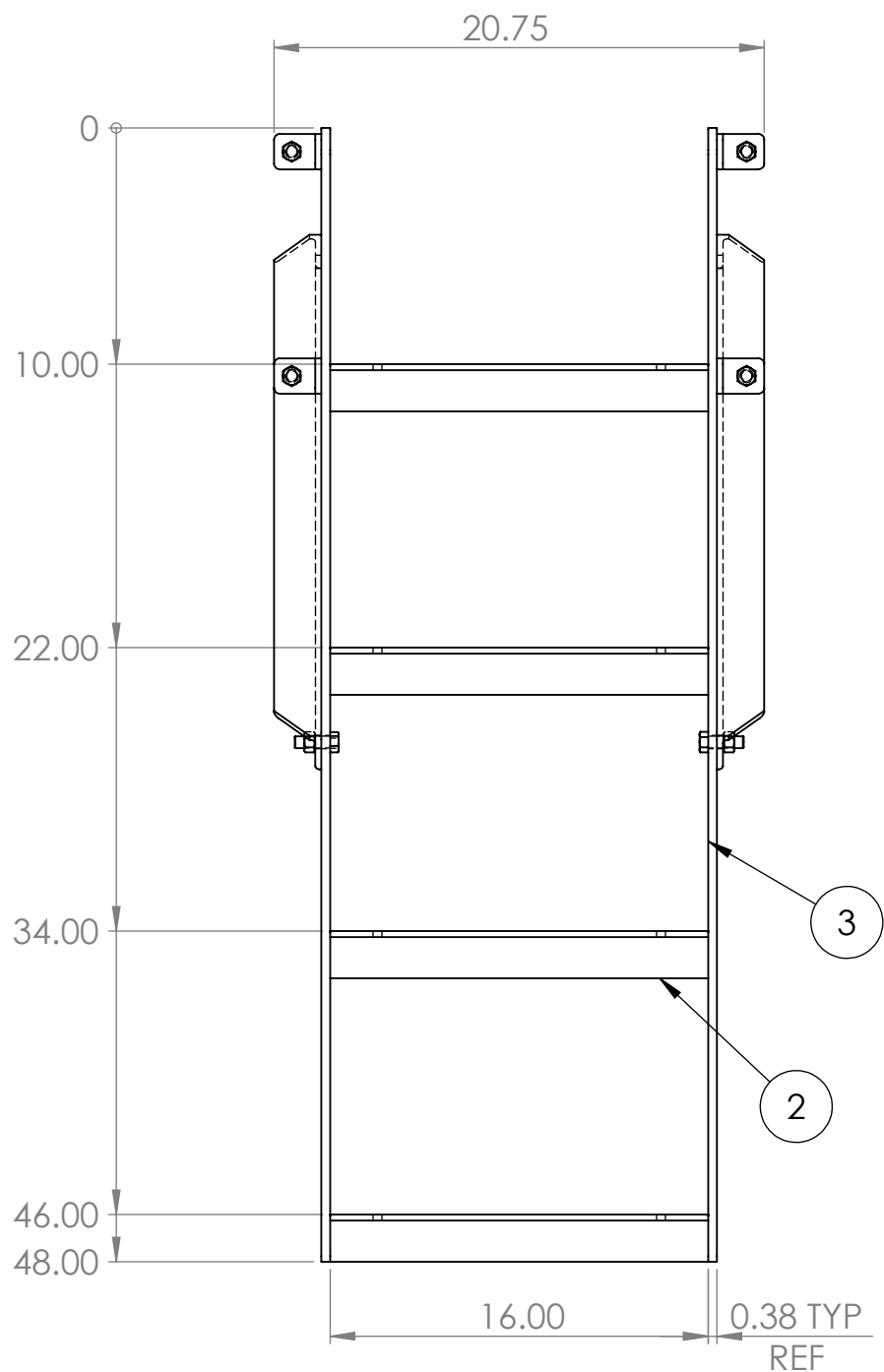

DETAIL A
SCALE 1 : 4

PROPRIETARY AND CONFIDENTIAL
 THE INFORMATION CONTAINED IN THIS DRAWING IS THE SOLE PROPERTY OF <INSERT COMPANY NAME HERE>. ANY REPRODUCTION IN PART OR AS A WHOLE WITHOUT THE WRITTEN PERMISSION OF <INSERT COMPANY NAME HERE> IS PROHIBITED.

		UNLESS OTHERWISE SPECIFIED:	NAME	DATE	KAMLOOPS WATERSKI CLUB	
		DIMENSIONS ARE IN INCHES	DRAWN	PD	23-11-12	TITLE:
		TOLERANCES:	CHECKED			WELDMENT, ASSEMBLY
		FRACTIONAL ±	ENG APPR.			SIZE DWG. NO. REV
		ANGULAR: MACH ± BEND ±	MFG APPR.			B jump ladder A
		TWO PLACE DECIMAL ±	Q.A.			SCALE: 1:8 WEIGHT: SHEET 1 OF 1
		THREE PLACE DECIMAL ±	COMMENTS:			
NEXT ASSY	USED ON	MATERIAL				
		FINISH				
APPLICATION		DO NOT SCALE DRAWING				

4

3

2

1

B

B

A

A

2

1

ITEM NO.	PART NUMBER	Material
1	L2x2x0.25x16	ANGLE, 2X2X1/4 - 16" LONG

B

B

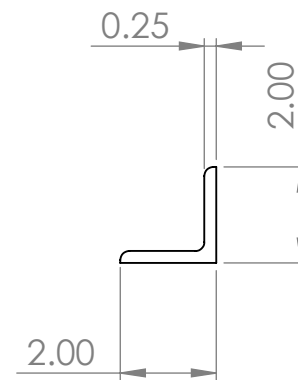
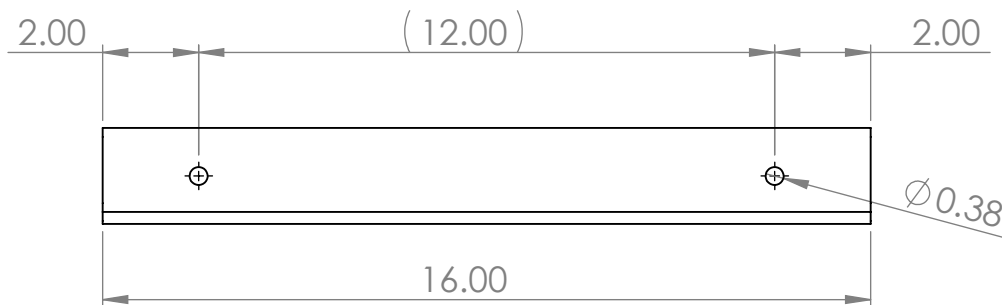

QTY 4

A

A

PROPRIETARY AND CONFIDENTIAL
 THE INFORMATION CONTAINED IN THIS DRAWING IS THE SOLE PROPERTY OF <INSERT COMPANY NAME HERE>. ANY REPRODUCTION IN PART OR AS A WHOLE WITHOUT THE WRITTEN PERMISSION OF <INSERT COMPANY NAME HERE> IS PROHIBITED.

		UNLESS OTHERWISE SPECIFIED:		NAME	DATE
		DIMENSIONS ARE IN INCHES	DRAWN	PD	23-11-12
		TOLERANCES:	CHECKED		
		FRACTIONAL \pm	ENG APPR.		
		ANGULAR: MACH \pm BEND \pm	MFG APPR.		
		TWO PLACE DECIMAL \pm	Q.A.		
		THREE PLACE DECIMAL \pm	COMMENTS:		
		INTERPRET GEOMETRIC TOLERANCING PER:			
		MATERIAL			
		ANGLE, 2X2X1/4 - 16" LONG			
		FINISH			
NEXT ASSY	USED ON				
APPLICATION		DO NOT SCALE DRAWING			

KAMLOOPS WATERSKI CLUB

TITLE:
LADDER RUNG

SIZE	DWG. NO.	REV
A	ANGLE	A

SCALE: 1:4	WEIGHT:	SHEET 1 OF 2
------------	---------	--------------

2

1

2

1

ITEM NO.	PART NUMBER	Material
1	L2x2x0.25x30	ANGLE 2X2X1/4 - 30" LONG

B

B

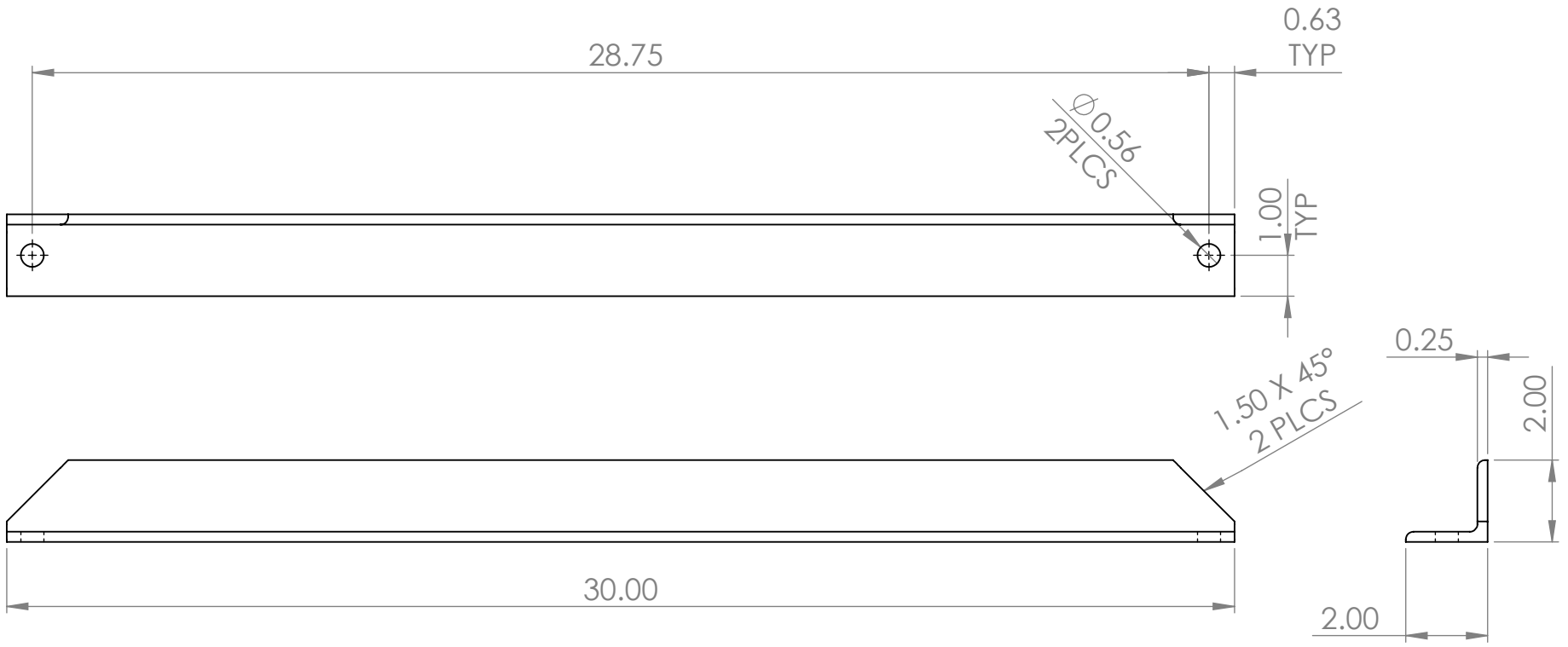

A

A

QTY 2

PROPRIETARY AND CONFIDENTIAL
 THE INFORMATION CONTAINED IN THIS DRAWING IS THE SOLE PROPERTY OF <INSERT COMPANY NAME HERE>. ANY REPRODUCTION IN PART OR AS A WHOLE WITHOUT THE WRITTEN PERMISSION OF <INSERT COMPANY NAME HERE> IS PROHIBITED.

		UNLESS OTHERWISE SPECIFIED:		NAME	DATE
		DIMENSIONS ARE IN INCHES	DRAWN	PD	23-11-12
		TOLERANCES:	CHECKED		
		FRACTIONAL ±	ENG APPR.		
		ANGULAR: MACH ± BEND ±	MFG APPR.		
		TWO PLACE DECIMAL ±	Q.A.		
		THREE PLACE DECIMAL ±	COMMENTS:		
		INTERPRET GEOMETRIC TOLERANCING PER:			
		MATERIAL			
		ANGLE, 2X2X1/4 - 16" LONG			
		FINISH			
NEXT ASSY	USED ON				
APPLICATION		DO NOT SCALE DRAWING			

KAMLOOPS WATERSKI CLUB		
TITLE:		
BRACE		
SIZE	DWG. NO.	REV
A	ANGLE	A
SCALE: 1:4	WEIGHT:	SHEET 2 OF 2

2

1

2

1

ITEM NO.	PART NUMBER	Material
1	mounting tab	FLAT BAR 1/4 X 1 1/2

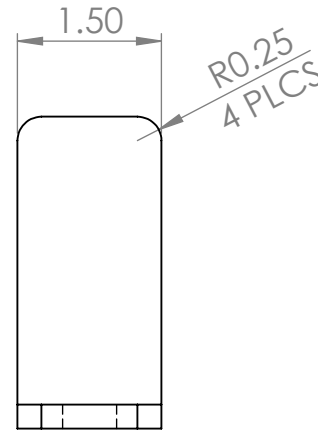
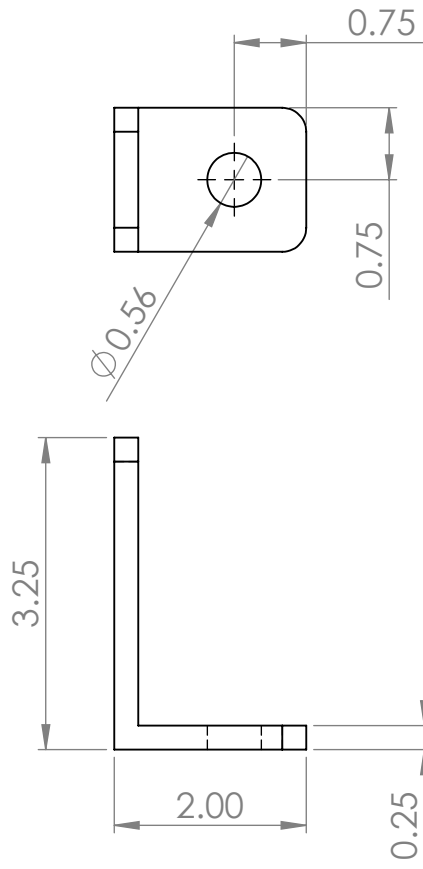

QTY 4

PROPRIETARY AND CONFIDENTIAL
 THE INFORMATION CONTAINED IN THIS DRAWING IS THE SOLE PROPERTY OF <INSERT COMPANY NAME HERE>. ANY REPRODUCTION IN PART OR AS A WHOLE WITHOUT THE WRITTEN PERMISSION OF <INSERT COMPANY NAME HERE> IS PROHIBITED.

		UNLESS OTHERWISE SPECIFIED:		NAME	DATE
		DIMENSIONS ARE IN INCHES	DRAWN	PD	23-11-12
		TOLERANCES:	CHECKED		
		FRACTIONAL \pm	ENG APPR.		
		ANGULAR: MACH \pm BEND \pm	MFG APPR.		
		TWO PLACE DECIMAL \pm	Q.A.		
		THREE PLACE DECIMAL \pm	COMMENTS:		
		INTERPRET GEOMETRIC TOLERANCING PER:			
		MATERIAL			
		FLAT BAR 1/4 X 1 1/2			
NEXT ASSY	USED ON	FINISH			
APPLICATION		DO NOT SCALE DRAWING			

KAMLOOPS WATERSKI CLUB

TITLE:
MOUNTING TAB

SIZE	DWG. NO.	REV
A	MOUNTING TAB	A
SCALE: 1:2	WEIGHT:	SHEET 1 OF 1

2

1

2

1

ITEM NO.	PART NUMBER	Material
1	side frame	FLAT BAR 3/8 X 2

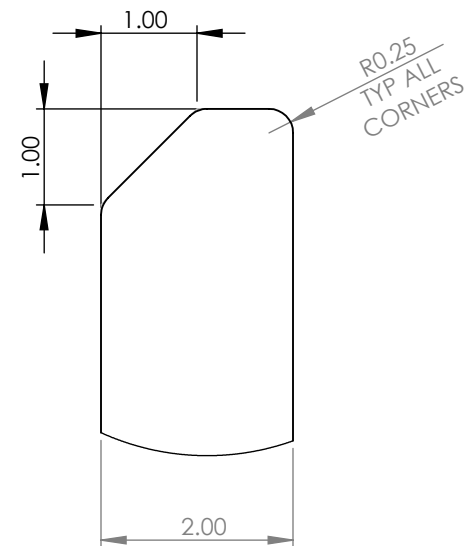
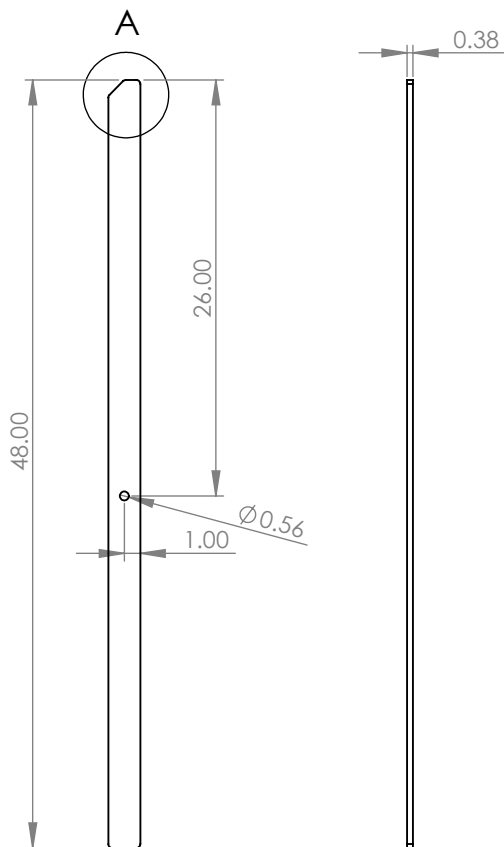

DETAIL A
SCALE 1 : 2

QTY 2

B

B

A

A

PROPRIETARY AND CONFIDENTIAL
THE INFORMATION CONTAINED IN THIS DRAWING IS THE SOLE PROPERTY OF <INSERT COMPANY NAME HERE>. ANY REPRODUCTION IN PART OR AS A WHOLE WITHOUT THE WRITTEN PERMISSION OF <INSERT COMPANY NAME HERE> IS PROHIBITED.

		UNLESS OTHERWISE SPECIFIED:	NAME	DATE
		DIMENSIONS ARE IN INCHES TOLERANCES: FRACTIONAL \pm ANGULAR: MACH \pm BEND \pm TWO PLACE DECIMAL \pm THREE PLACE DECIMAL \pm	DRAWN PD	23-11-12
		INTERPRET GEOMETRIC TOLERANCING PER:	CHECKED	
		MATERIAL FLAT BAR 3/8 X 2	ENG APPR.	
		FINISH	MFG APPR.	
NEXT ASSY	USED ON		Q.A.	
APPLICATION		DO NOT SCALE DRAWING	COMMENTS:	

KAMLOOPS WATERSKI CLUB

TITLE:

SIDE FRAME

SIZE	DWG. NO.	REV
A	SIDE FRAME	A
SCALE: 1:12	WEIGHT:	SHEET 1 OF 1

2

1