

4

3

2

1

ITEM NO.	PART NUMBER	DESCRIPTION	QTY.
1	P001-01	Bottom Mounting Plate	2
2	P002-01	Mounting Tab	8
3	Preferred Narrow FW 0.375		8
4	HBOLT 0.3750-16x2x1-N		4
5	P003-01	JACKING ROD	2
6	TS2x2x0.1875x18		2
7	HNUT 1.5000-12-D-N		2
8	TS2.5x2.5x0.1875x22		2
9	P004-01	Top Mount Plate	2
10	HBOLT 0.3750-16x1.25x1-N		4
11	HNUT 0.3750-16-D-N		4
12	P005-01	TOP ADJUSTMENT TUBE	2
13	L1.5x1.5x0.25x9.25		4
14	5/8 HITCH PIN - 3.5"		6

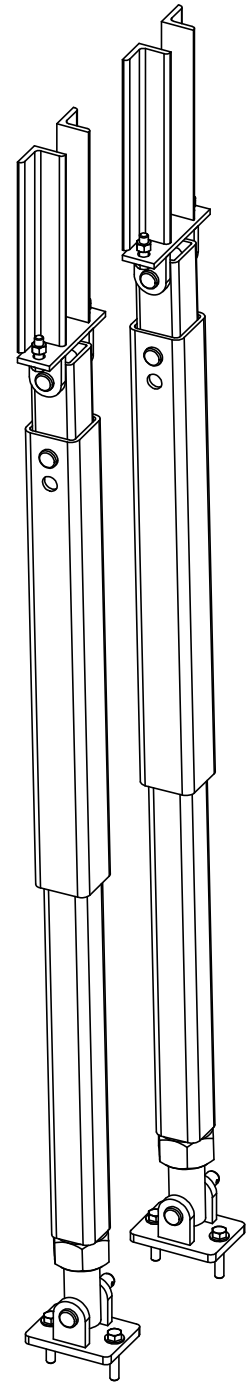

COMPLETE PARTS BOM QTY'S

QTY 1
ALL FASTENERS SS -
DETERMINE LENGTH ON ASSY

PROPRIETARY AND CONFIDENTIAL
THE INFORMATION CONTAINED IN THIS DRAWING IS THE SOLE PROPERTY OF <INSERT COMPANY NAME HERE>. ANY REPRODUCTION IN PART OR AS A WHOLE WITHOUT THE WRITTEN PERMISSION OF <INSERT COMPANY NAME HERE> IS PROHIBITED.

		UNLESS OTHERWISE SPECIFIED:		NAME	DATE	Kamloops Waterski Club			
		DIMENSIONS ARE IN INCHES		DRAWN	PD	24/1/1	TITLE: LOCKING POST, COMPLETE ASSY		
		TOLERANCES:		CHECKED					
		FRACTIONAL ±		ENG APPR.					
		ANGULAR: MACH ± BEND ±		MFG APPR.					
		TWO PLACE DECIMAL ±		Q.A.			SIZE	DWG. NO.	REV
		THREE PLACE DECIMAL ±		COMMENTS:			B	A006-01	A
		INTERPRET GEOMETRIC TOLERANCING PER:					SCALE: 1:8	WEIGHT:	SHEET 1 OF 1
		MATERIAL							
NEXT ASSY	USED ON	FINISH							
APPLICATION		DO NOT SCALE DRAWING							

4

3

2

1

4

3

2

1

ITEM NO.	PART NUMBER	DESCRIPTION	QTY.
1	A002-01	Bottom Mounting Weldment	1
2	P003-01	JACKING ROD	1
3	A004-01	Lower Tube Weldment	1
4	A005-01	Top Assembly & Weldment	1
5	P005-01	TOP ADJUSTMENT TUBE	1
6	L1.5x1.5x0.25x9.25		2
7	5/8 HITCH PIN - 3.5"		3

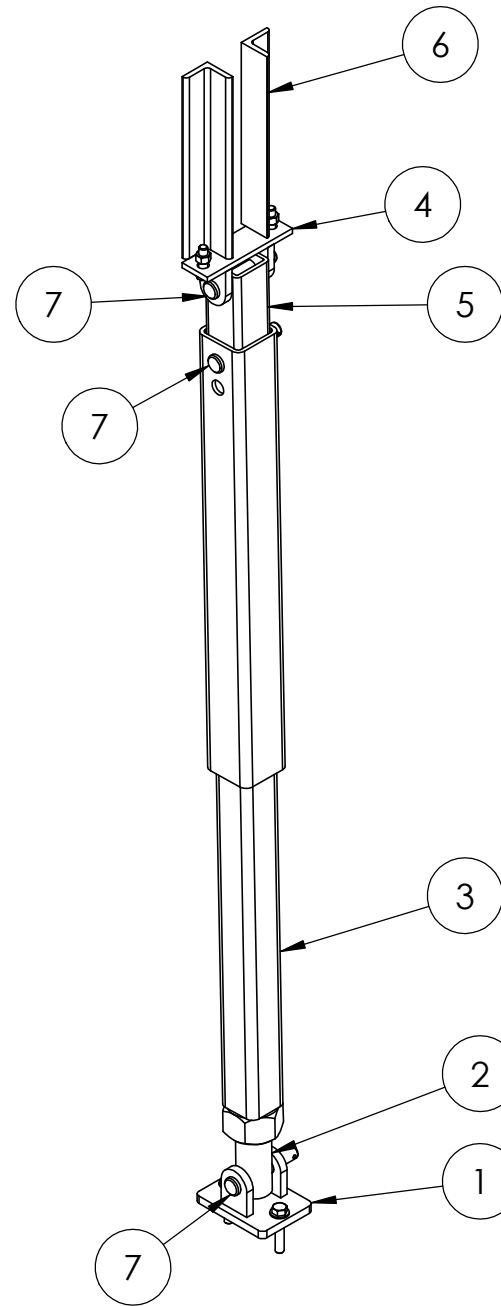

6 REINFORCEMENT STRUTS - FIELD WELD

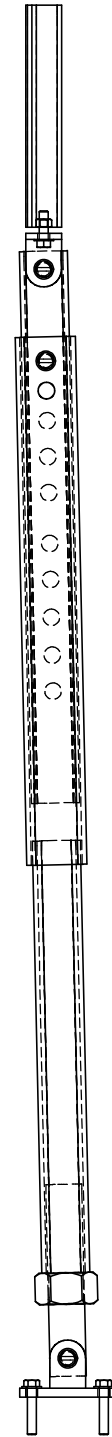

QTY 2
ALL FASTENERS SS -
DETERMINE LENGTH ON ASSY

PROPRIETARY AND CONFIDENTIAL
THE INFORMATION CONTAINED IN THIS DRAWING IS THE SOLE PROPERTY OF <INSERT COMPANY NAME HERE>. ANY REPRODUCTION IN PART OR AS A WHOLE WITHOUT THE WRITTEN PERMISSION OF <INSERT COMPANY NAME HERE> IS PROHIBITED.

		UNLESS OTHERWISE SPECIFIED:		NAME	DATE	Kamloops Waterski Club	
		DIMENSIONS ARE IN INCHES		DRAWN	PD	TITLE:	
		TOLERANCES:		CHECKED		Locking Post Assembly	
		FRACTIONAL ±		ENG APPR.		SIZE DWG. NO. REV	
		ANGULAR: MACH ± BEND ±		MFG APPR.		B A001-01 A	
		TWO PLACE DECIMAL ±		Q.A.		SCALE: 1:8 WEIGHT: SHEET 1 OF 1	
		THREE PLACE DECIMAL ±		COMMENTS:			
		INTERPRET GEOMETRIC TOLERANCING PER:					
		MATERIAL					
NEXT ASSY	USED ON	FINISH					
APPLICATION		DO NOT SCALE DRAWING					

4

3

2

1

4

3

2

1

ITEM NO.	PART NUMBER	DESCRIPTION	QTY.
1	A003-01	Bottom Mounting Weldment	1
2	Preferred Narrow FW 0.375		2
3	HBOLT 0.3750-16x2x1-N		2

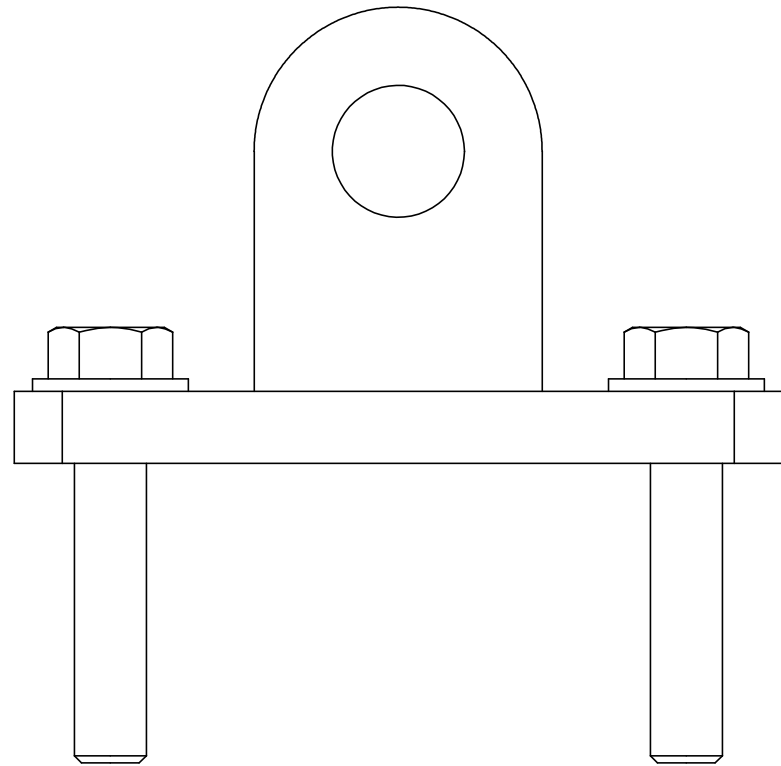
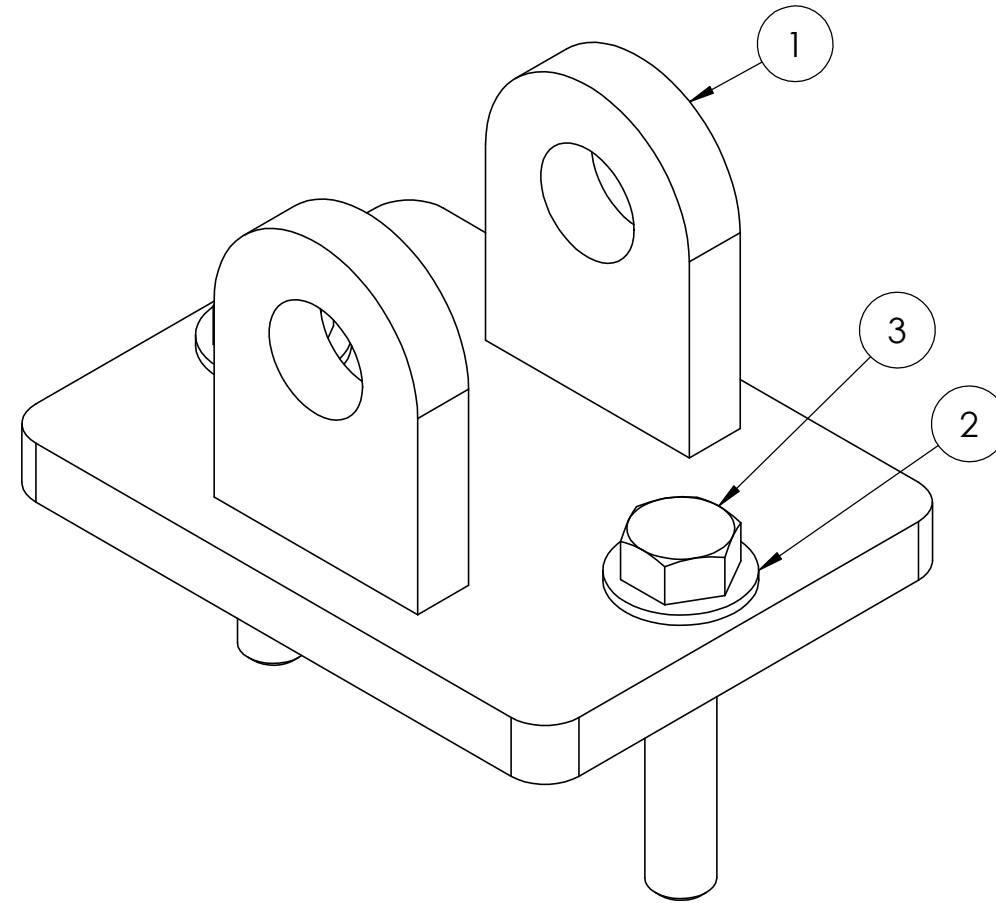
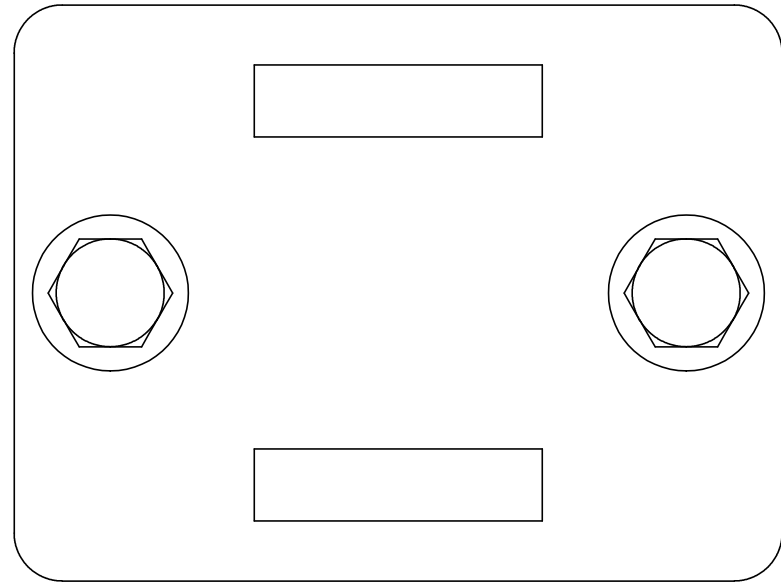

QTY 2
ALL FASTENERS STAINLESS
DETERMINE LENGTH ON ASSY

PROPRIETARY AND CONFIDENTIAL
THE INFORMATION CONTAINED IN THIS DRAWING IS THE SOLE PROPERTY OF <INSERT COMPANY NAME HERE>. ANY REPRODUCTION IN PART OR AS A WHOLE WITHOUT THE WRITTEN PERMISSION OF <INSERT COMPANY NAME HERE> IS PROHIBITED.

		UNLESS OTHERWISE SPECIFIED:	NAME	DATE	Kamloops Waterski Club	
		DIMENSIONS ARE IN INCHES	DRAWN	PD	24/1/1	TITLE: Bottom Mounting Weldment
		TOLERANCES:	CHECKED			
		FRACTIONAL ±	ENG APPR.			
		ANGULAR: MACH ± BEND ±	MFG APPR.			
		TWO PLACE DECIMAL ±	Q.A.			
		THREE PLACE DECIMAL ±	COMMENTS:			
		INTERPRET GEOMETRIC TOLERANCING PER:				
		MATERIAL				
NEXT ASSY	USED ON	FINISH				SIZE DWG. NO. REV B A002-01 A
APPLICATION		DO NOT SCALE DRAWING				SCALE: 1:1 WEIGHT: SHEET 1 OF 1

4

3

2

1

B

B

A

A

4

3

2

1

ITEM NO.	PART NUMBER	DESCRIPTION	QTY.
1	P001-01	Bottom Mounting Plate	1
2	P002-01	Mounting Tab	2

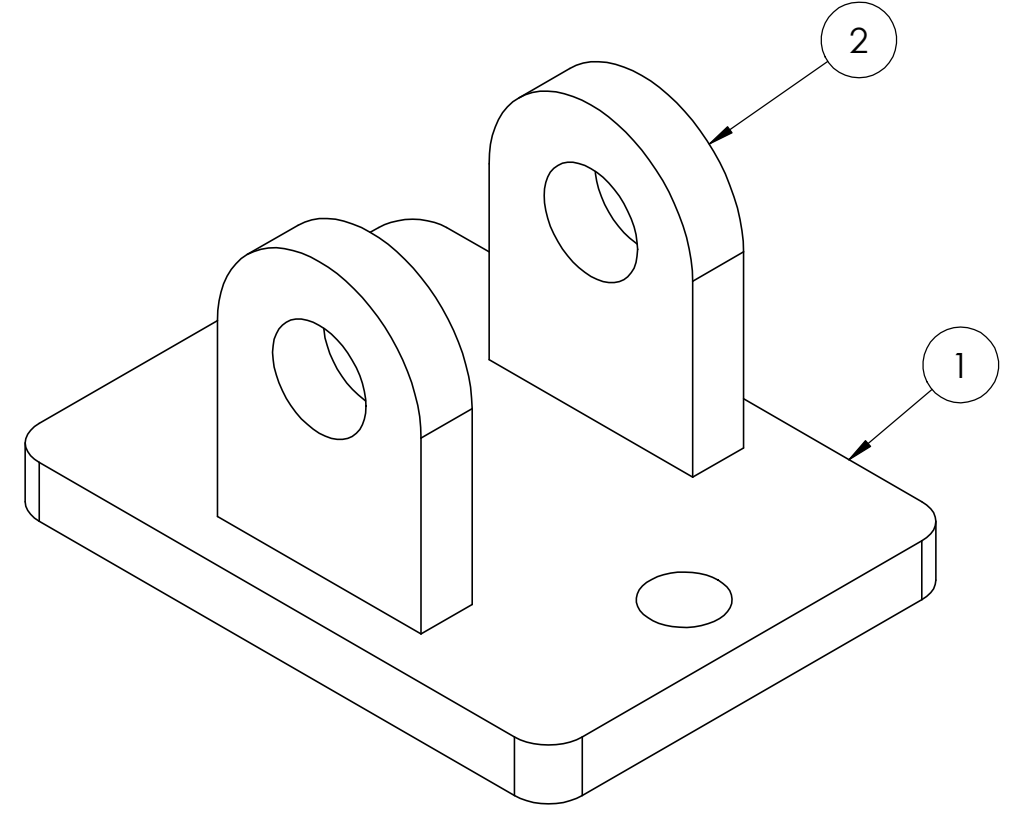
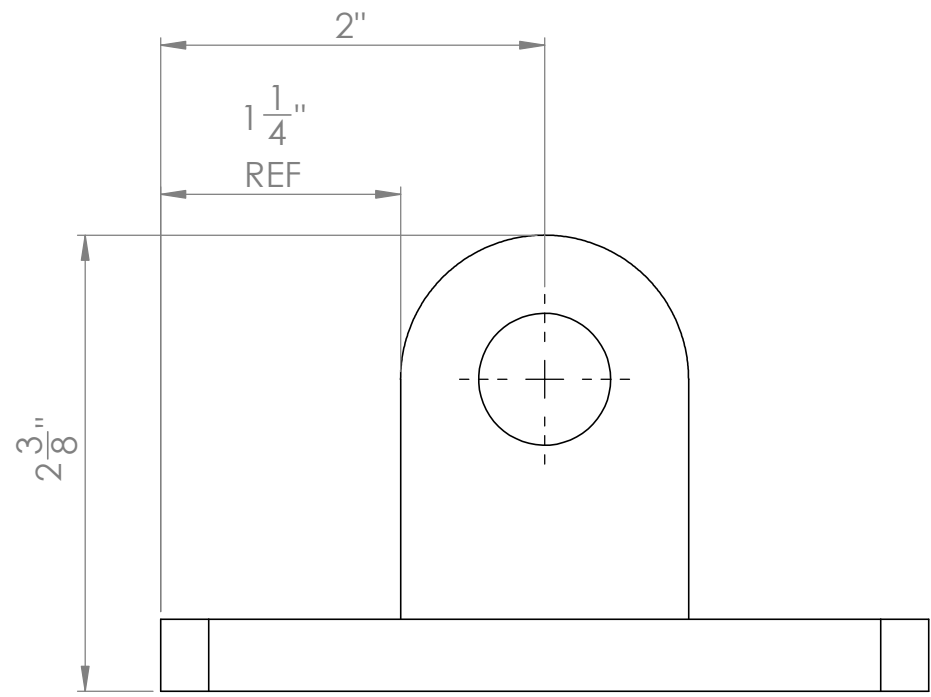
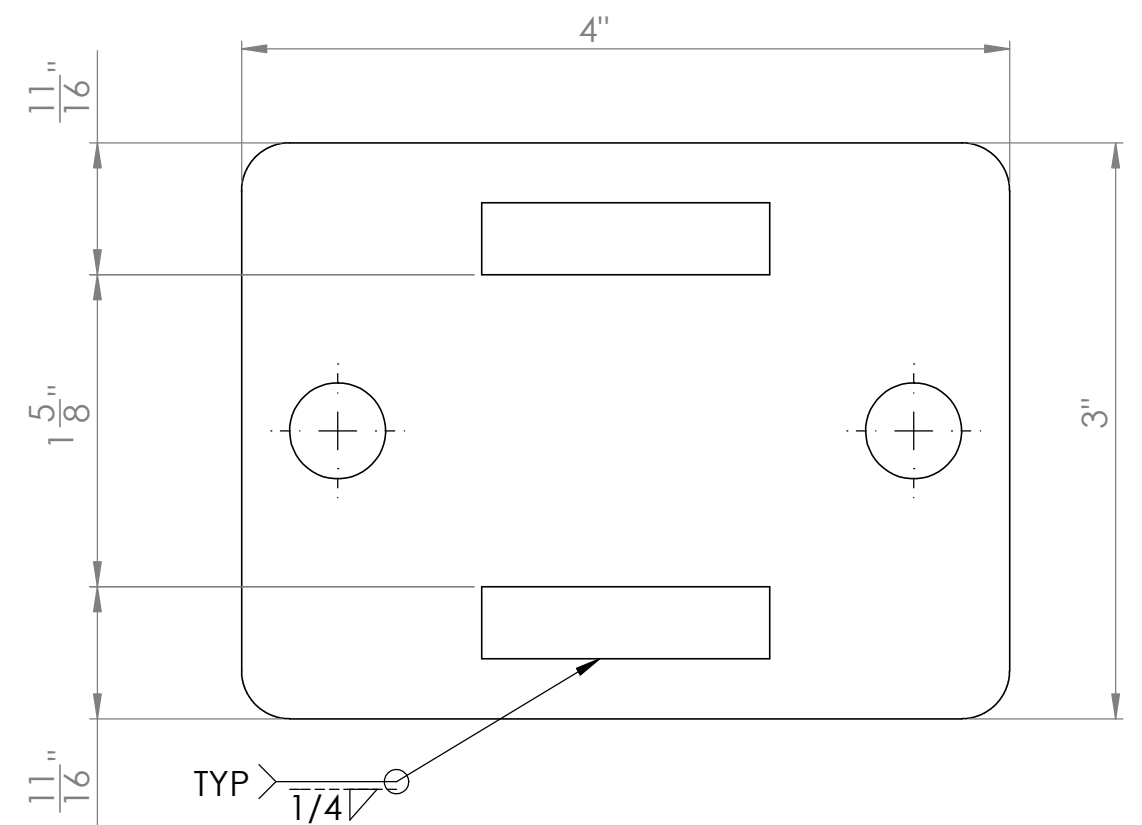

QTY 2

PROPRIETARY AND CONFIDENTIAL
 THE INFORMATION CONTAINED IN THIS DRAWING IS THE SOLE PROPERTY OF <INSERT COMPANY NAME HERE>. ANY REPRODUCTION IN PART OR AS A WHOLE WITHOUT THE WRITTEN PERMISSION OF <INSERT COMPANY NAME HERE> IS PROHIBITED.

UNLESS OTHERWISE SPECIFIED:		NAME	DATE	Kamloops Waterski Club	
DIMENSIONS ARE IN INCHES		DRAWN	PD	TITLE: Bottom Mounting Weldment	
TOLERANCES:		CHECKED		SIZE B DWG. NO. A003-01 REV A	
FRACTIONAL ±		ENG APPR.		SCALE: 1:1 WEIGHT: SHEET 1 OF 1	
ANGULAR: MACH ± BEND ±		MFG APPR.			
TWO PLACE DECIMAL ±		Q.A.			
THREE PLACE DECIMAL ±		COMMENTS:			
INTERPRET GEOMETRIC TOLERANCING PER:					
MATERIAL					
NEXT ASSY	USED ON	FINISH			
APPLICATION		DO NOT SCALE DRAWING			

4

3

2

1

ITEM NO.	PART NUMBER	DESCRIPTION	QTY.
1	TS2x2x0.1875x18		1
2	TS2.5x2.5x0.1875x22		1
3	HNUT 1.5000-12-D-N		1

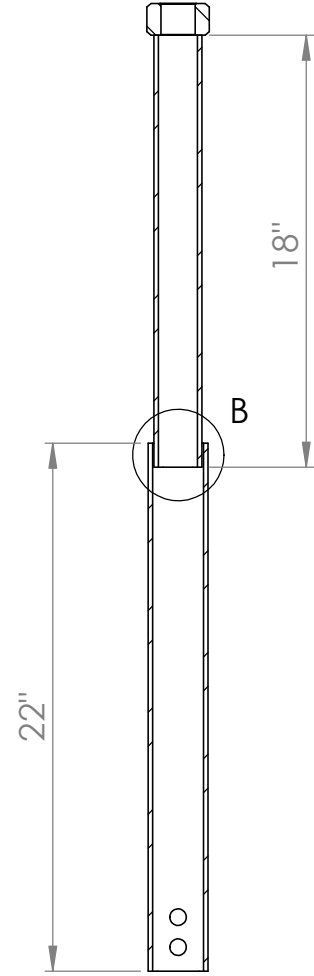
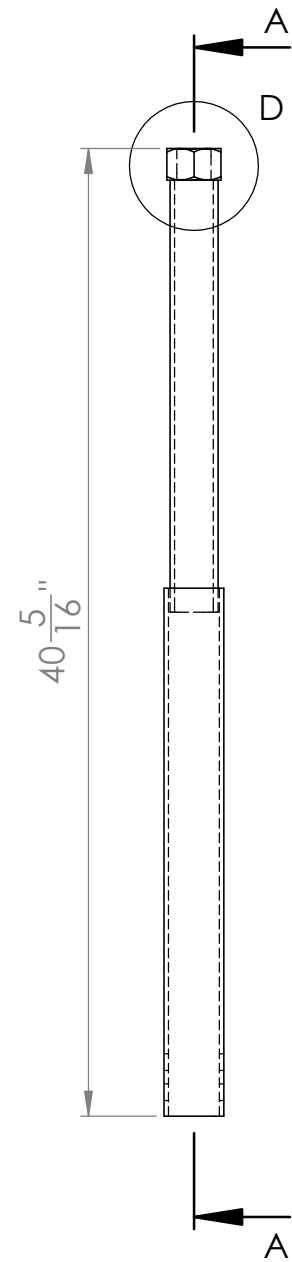

SECTION A-A

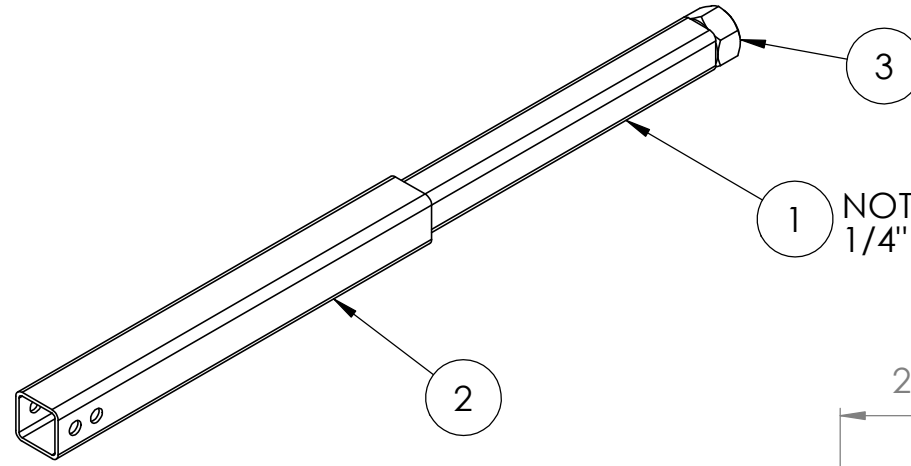

NOTE: TS2X2 CAN BE 1/4" THK

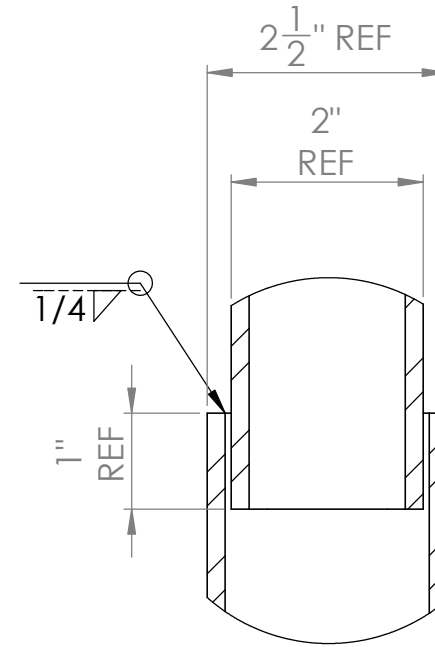

DETAIL B
SCALE 1 : 2

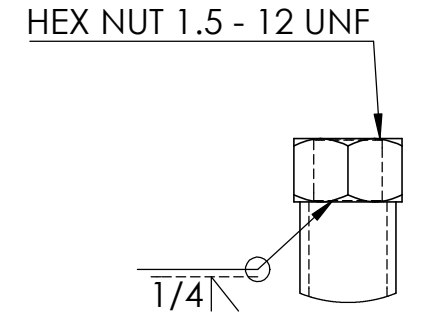

DETAIL D
SCALE 1 : 4

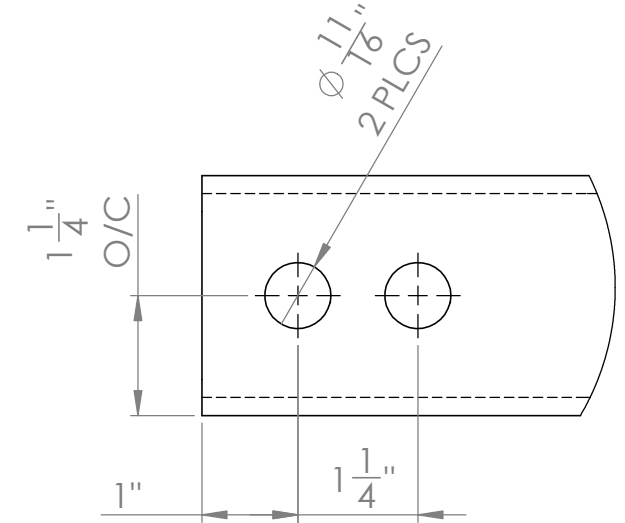

DETAIL C
SCALE 1 : 2

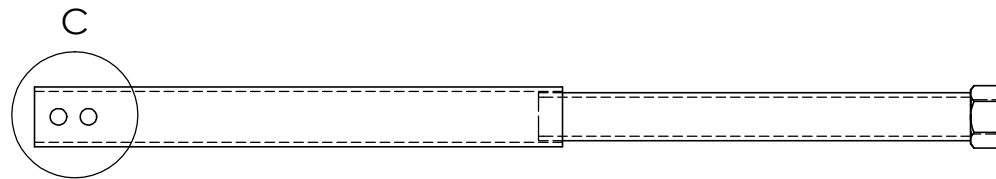

QTY 2

PROPRIETARY AND CONFIDENTIAL

THE INFORMATION CONTAINED IN THIS DRAWING IS THE SOLE PROPERTY OF <INSERT COMPANY NAME HERE>. ANY REPRODUCTION IN PART OR AS A WHOLE WITHOUT THE WRITTEN PERMISSION OF <INSERT COMPANY NAME HERE> IS PROHIBITED.

		UNLESS OTHERWISE SPECIFIED:		NAME	DATE	Kamloops Waterski Club	
		DIMENSIONS ARE IN INCHES		DRAWN	PD	24/1/1	TITLE:
		TOLERANCES:		CHECKED			Lower Tube Weldment
		FRACTIONAL ±		ENG APPR.			
		ANGULAR: MACH ± BEND ±		MFG APPR.			
		TWO PLACE DECIMAL ±		Q.A.			
		THREE PLACE DECIMAL ±		COMMENTS:			
		INTERPRET GEOMETRIC TOLERANCING PER:					
		MATERIAL					
		FINISH					
NEXT ASSY	USED ON						
APPLICATION		DO NOT SCALE DRAWING					
SIZE	DWG. NO.	REV					
B	A004-01	A					
SCALE: 1:8		WEIGHT:	SHEET 1 OF 1				

4

3

2

1

ITEM NO.	PART NUMBER	DESCRIPTION	QTY.
1	P004-01	Top Mount Plate	1
2	P002-01	Mounting Tab	2
3	Preferred Narrow FW 0.375		2
4	HBOLT 0.3750-16x1.25x1-N		2
5	HNUT 0.3750-16-D-N		2

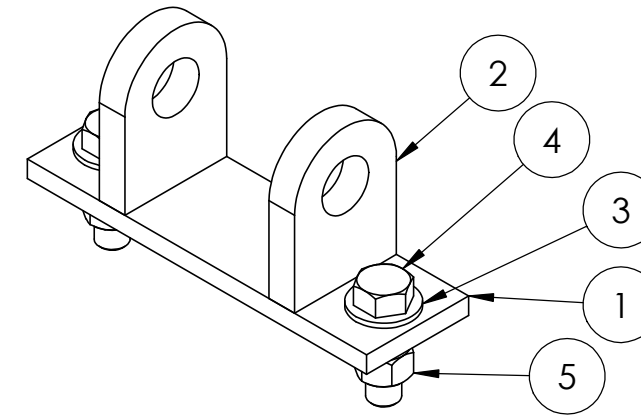
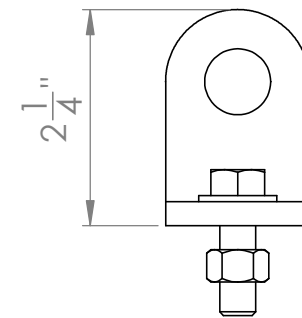
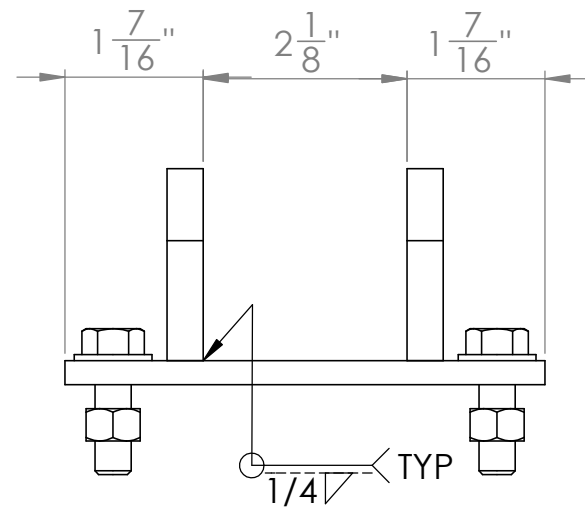
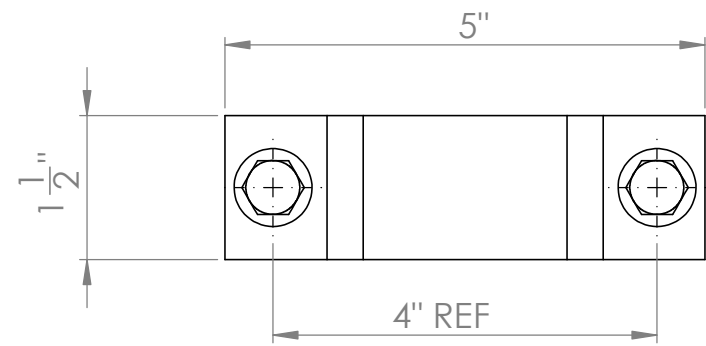

QTY 2
ALL FASTENERS STAINLESS

PROPRIETARY AND CONFIDENTIAL
THE INFORMATION CONTAINED IN THIS DRAWING IS THE SOLE PROPERTY OF <INSERT COMPANY NAME HERE>. ANY REPRODUCTION IN PART OR AS A WHOLE WITHOUT THE WRITTEN PERMISSION OF <INSERT COMPANY NAME HERE> IS PROHIBITED.

		UNLESS OTHERWISE SPECIFIED:	NAME	DATE	Kamloops Waterski Club	
		DIMENSIONS ARE IN INCHES	DRAWN	PD	TITLE: Top Assembly & Weldment	
		TOLERANCES:	CHECKED			
		FRACTIONAL ±	ENG APPR.			
		ANGULAR: MACH ± BEND ±	MFG APPR.			
		TWO PLACE DECIMAL ±	Q.A.			
		THREE PLACE DECIMAL ±	COMMENTS:			
		INTERPRET GEOMETRIC TOLERANCING PER:			SIZE	DWG. NO.
		MATERIAL			B	A005-01
NEXT ASSY	USED ON	FINISH			REV	A
APPLICATION		DO NOT SCALE DRAWING			SCALE: 1:2	WEIGHT:
						SHEET 1 OF 1

4

3

2

1

B

B

A

A

4

3

2

1

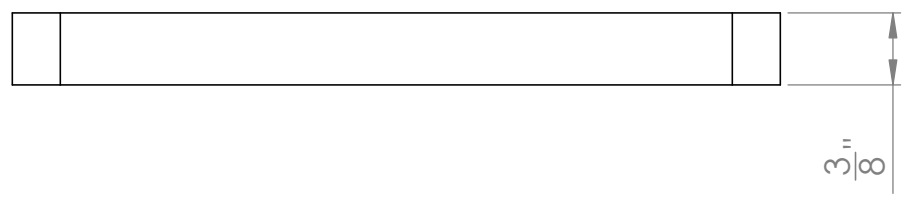
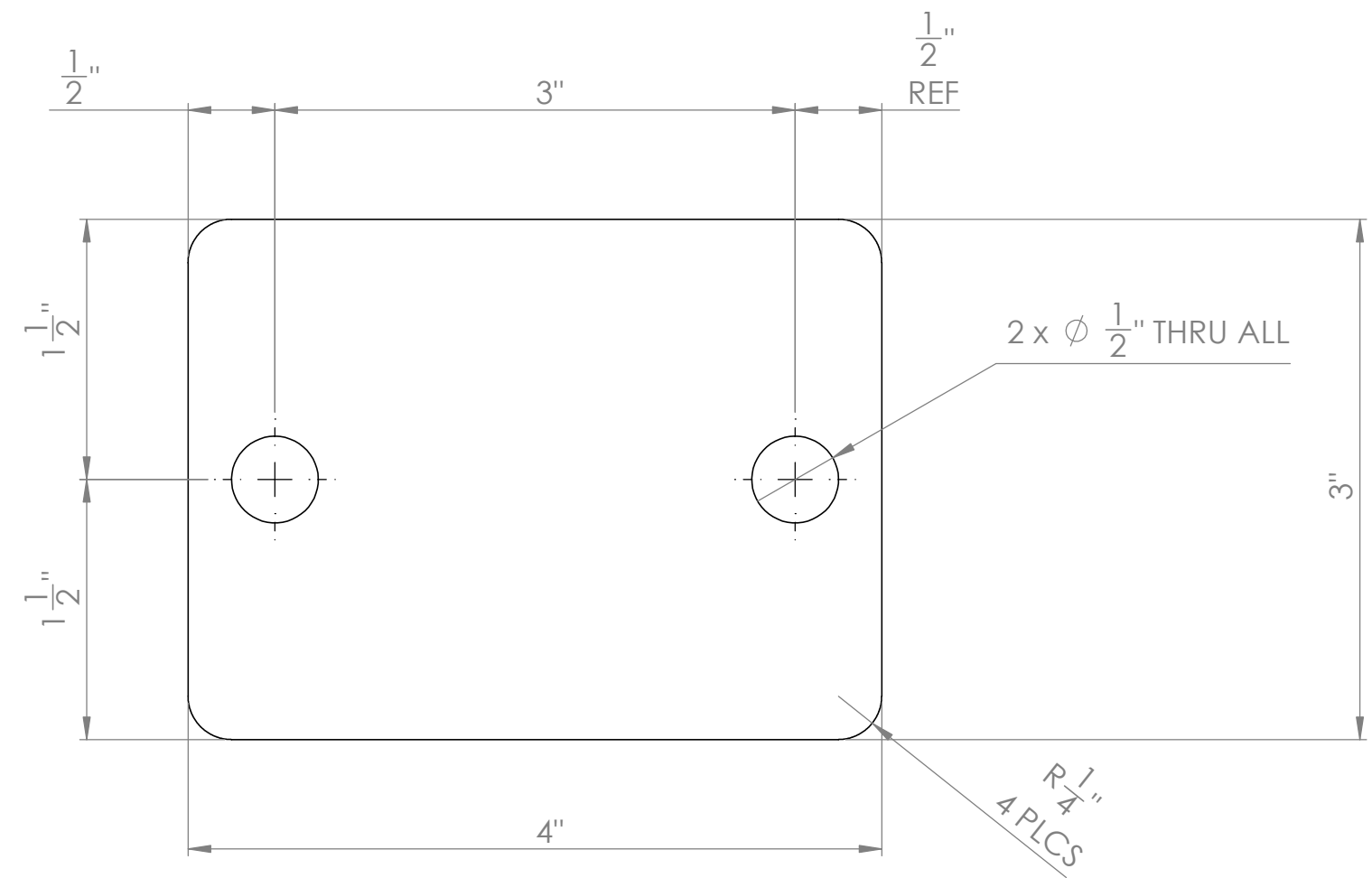

PROPRIETARY AND CONFIDENTIAL
 THE INFORMATION CONTAINED IN THIS DRAWING IS THE SOLE PROPERTY OF <INSERT COMPANY NAME HERE>. ANY REPRODUCTION IN PART OR AS A WHOLE WITHOUT THE WRITTEN PERMISSION OF <INSERT COMPANY NAME HERE> IS PROHIBITED.

		UNLESS OTHERWISE SPECIFIED:		NAME	DATE	Kamloops Waterski Club	
		DIMENSIONS ARE IN INCHES		DRAWN	PD	24/1/1	TITLE: Bottom Mounting Plate
		TOLERANCES:		CHECKED			
		FRACTIONAL ±		ENG APPR.			
		ANGULAR: MACH ± BEND ±		MFG APPR.			
		TWO PLACE DECIMAL ±		Q.A.			SIZE DWG. NO. REV B P001-01 A
		THREE PLACE DECIMAL ±		COMMENTS:			
		INTERPRET GEOMETRIC TOLERANCING PER:					SCALE: 1:1
		MATERIAL					WEIGHT:
NEXT ASSY	USED ON	FINISH					SHEET 1 OF 1
APPLICATION		DO NOT SCALE DRAWING					

QTY 2

4

3

2

1

4

3

2

1

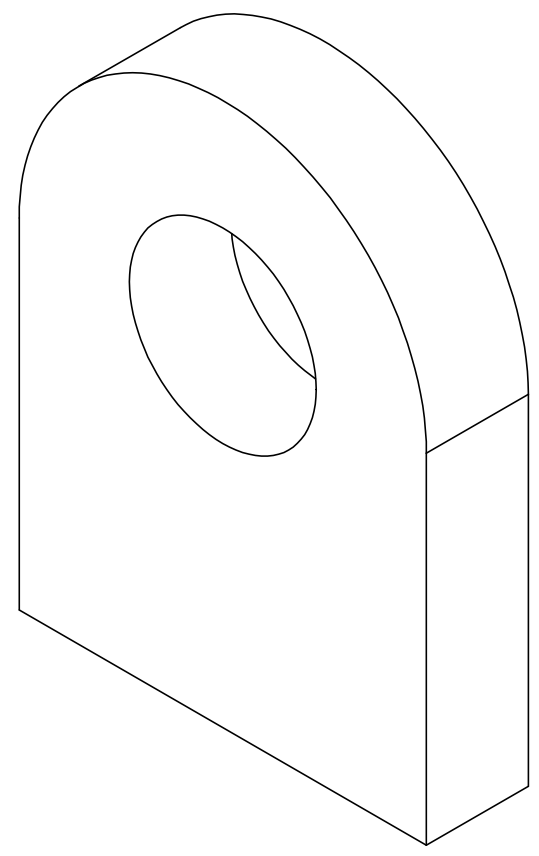
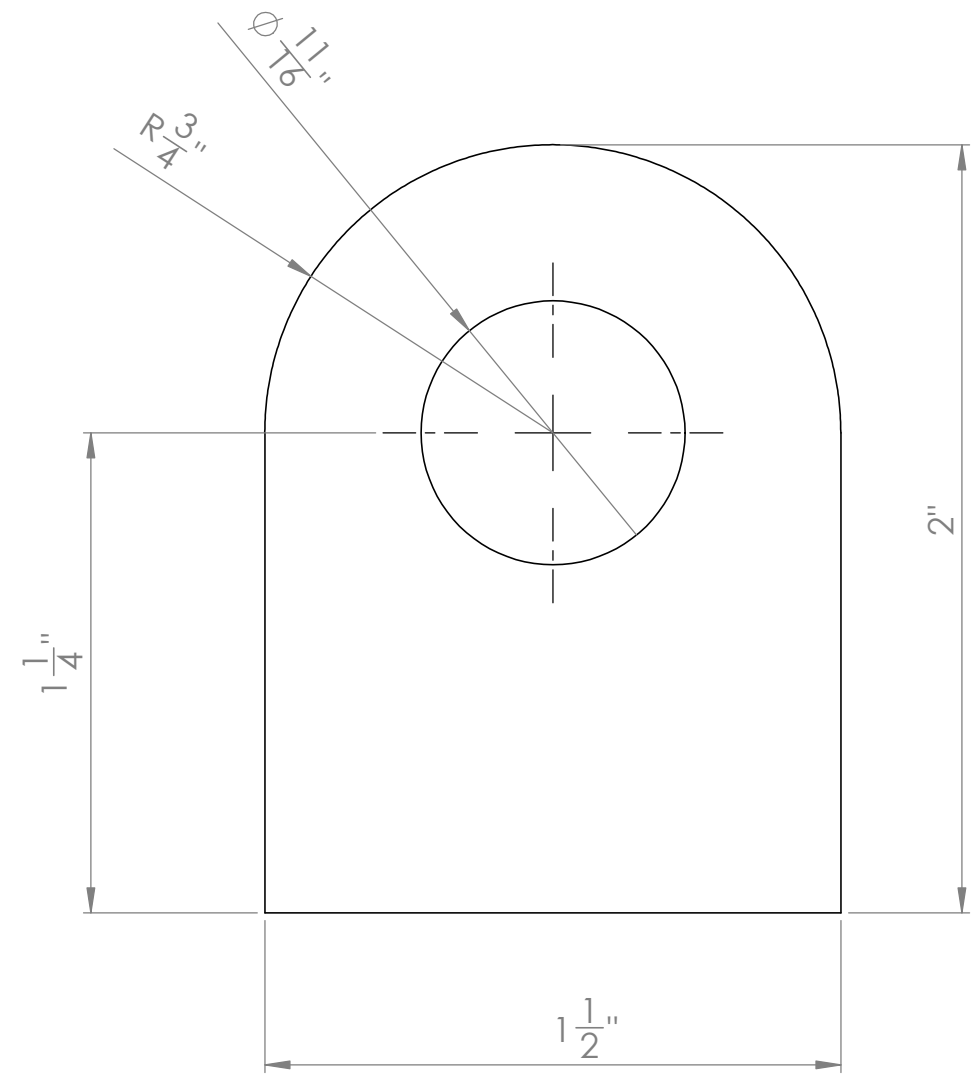
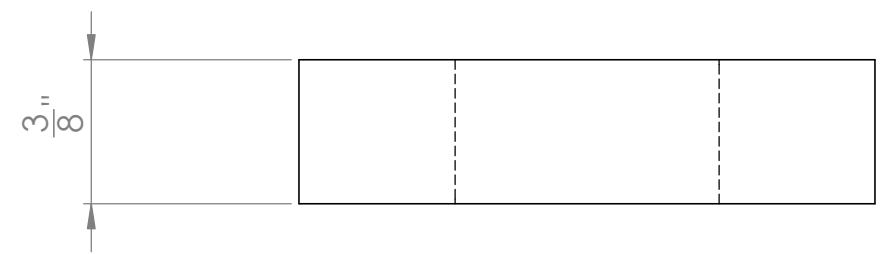

QTY 8

PROPRIETARY AND CONFIDENTIAL
 THE INFORMATION CONTAINED IN THIS DRAWING IS THE SOLE PROPERTY OF <INSERT COMPANY NAME HERE>. ANY REPRODUCTION IN PART OR AS A WHOLE WITHOUT THE WRITTEN PERMISSION OF <INSERT COMPANY NAME HERE> IS PROHIBITED.

		UNLESS OTHERWISE SPECIFIED:		NAME	DATE	Kamloops Waterski Club	
		DIMENSIONS ARE IN INCHES		DRAWN	PD	24/1/1	
		TOLERANCES:		CHECKED		TITLE: Mounting Tab	
		FRACTIONAL ±		ENG APPR.			
		ANGULAR: MACH ± BEND ±		MFG APPR.			
		TWO PLACE DECIMAL ±		Q.A.			
		THREE PLACE DECIMAL ±		COMMENTS:			
		INTERPRET GEOMETRIC TOLERANCING PER:					
		MATERIAL					
NEXT ASSY	USED ON	FINISH					
APPLICATION		DO NOT SCALE DRAWING					
SIZE	DWG. NO.	REV					
B	P002-01	A					
SCALE: 2:1		WEIGHT:		SHEET 1 OF 1			

4

3

2

1

B

B

A

A

4

3

2

1

B

B

A

A

NOTE: 1.5-12 UNF THREAD
USE ALL THREAD OR CUT BOLT

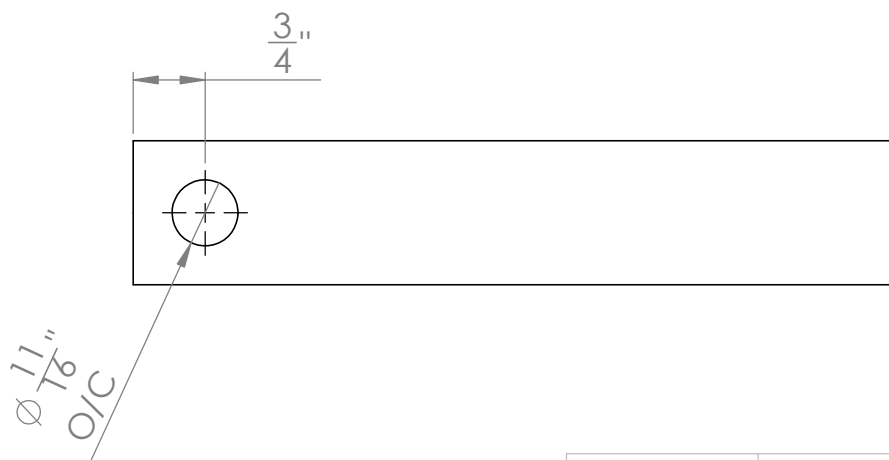
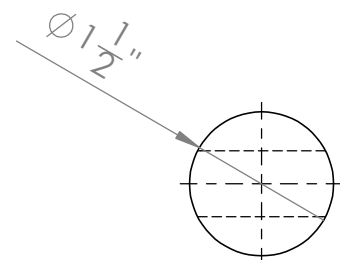
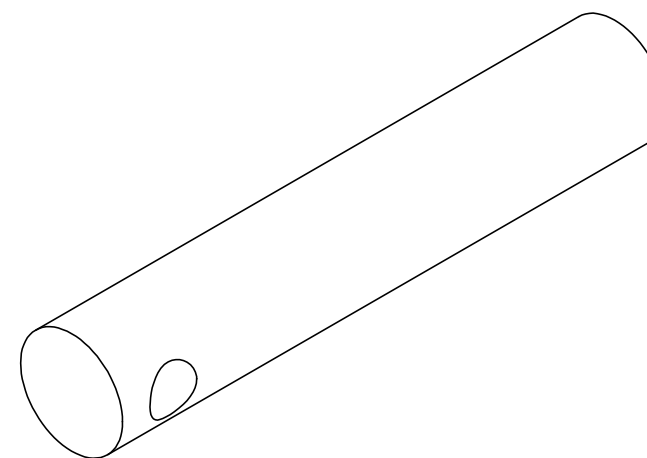
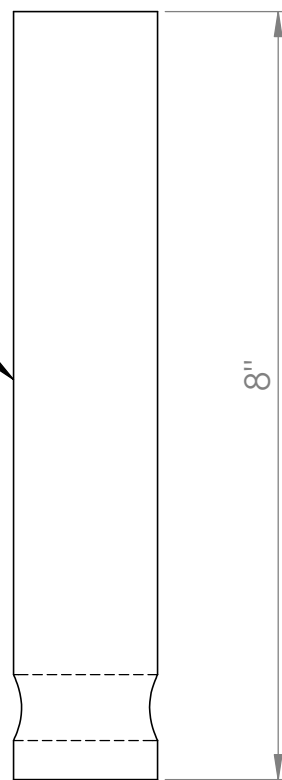

QTY 2

PROPRIETARY AND CONFIDENTIAL
 THE INFORMATION CONTAINED IN THIS DRAWING IS THE SOLE PROPERTY OF <INSERT COMPANY NAME HERE>. ANY REPRODUCTION IN PART OR AS A WHOLE WITHOUT THE WRITTEN PERMISSION OF <INSERT COMPANY NAME HERE> IS PROHIBITED.

		UNLESS OTHERWISE SPECIFIED:	NAME	DATE	Kamloops Waterski Club	
		DIMENSIONS ARE IN INCHES	DRAWN	PD	24/1/1	TITLE: JACKING ROD
		TOLERANCES:	CHECKED			
		FRACTIONAL \pm	ENG APPR.			
		ANGULAR: MACH \pm BEND \pm	MFG APPR.			
		TWO PLACE DECIMAL \pm	Q.A.			
		THREE PLACE DECIMAL \pm	COMMENTS:			
		INTERPRET GEOMETRIC TOLERANCING PER:				
		MATERIAL				
NEXT ASSY	USED ON	FINISH				
APPLICATION		DO NOT SCALE DRAWING				
SIZE	DWG. NO.	REV				
B	P003-01	A				
SCALE: 1:2	WEIGHT:	SHEET 1 OF 1				

4

3

2

1

4

3

2

1

B

B

A

A

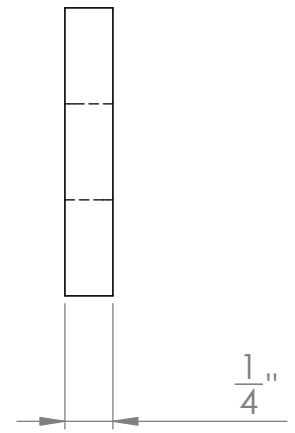
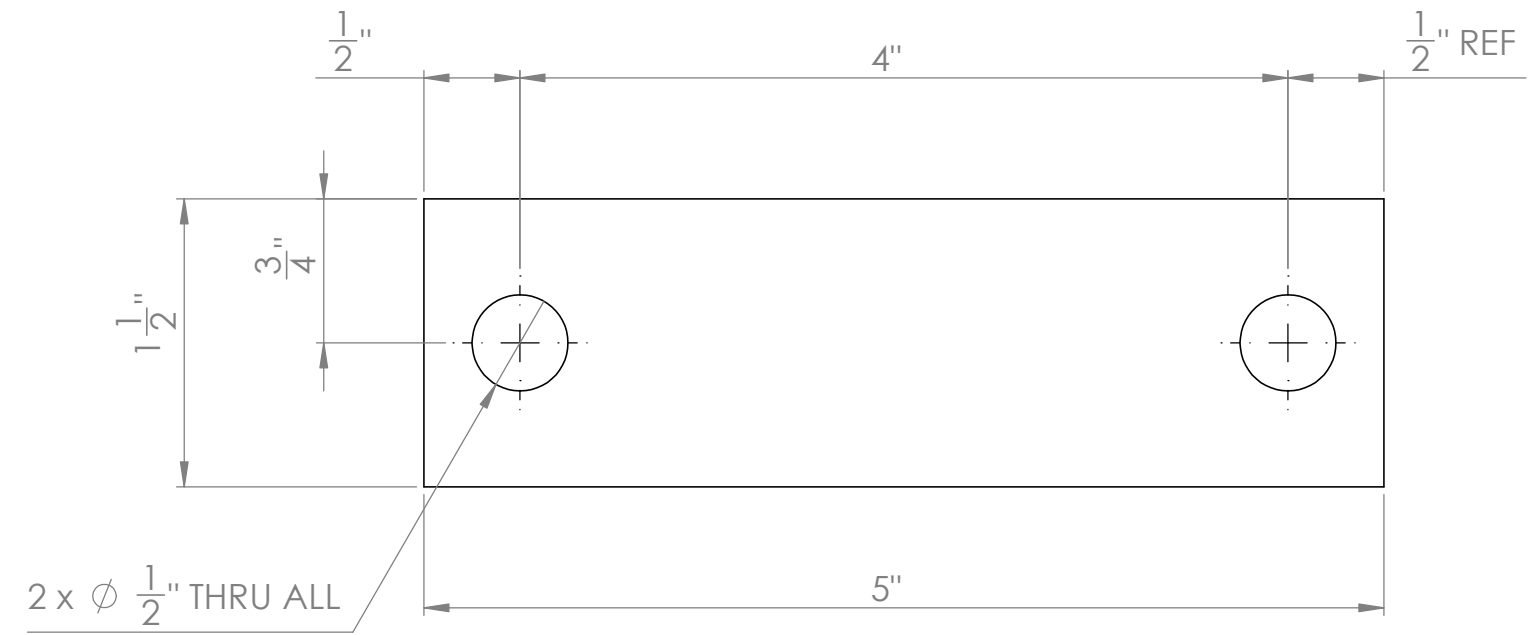
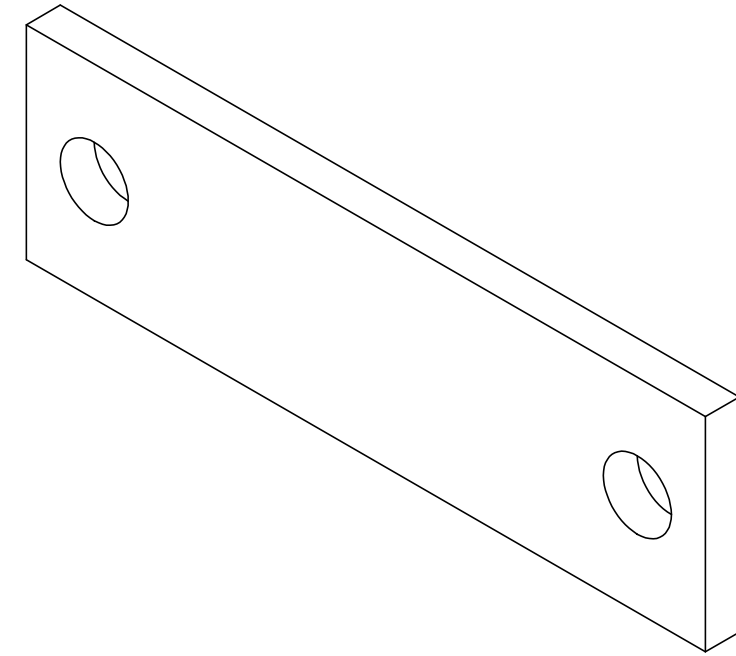

QTY 2

PROPRIETARY AND CONFIDENTIAL
 THE INFORMATION CONTAINED IN THIS DRAWING IS THE SOLE PROPERTY OF <INSERT COMPANY NAME HERE>. ANY REPRODUCTION IN PART OR AS A WHOLE WITHOUT THE WRITTEN PERMISSION OF <INSERT COMPANY NAME HERE> IS PROHIBITED.

		UNLESS OTHERWISE SPECIFIED:		NAME	DATE	Kamloops Waterski Club	
		DIMENSIONS ARE IN INCHES		DRAWN	PD	24/1/1	
		TOLERANCES:		CHECKED		TITLE: Top Mount Plate	
		FRACTIONAL ±		ENG APPR.			
		ANGULAR: MACH ± BEND ±		MFG APPR.			
		TWO PLACE DECIMAL ±		Q.A.			
		THREE PLACE DECIMAL ±		COMMENTS:			
		INTERPRET GEOMETRIC TOLERANCING PER:					
		MATERIAL					
		FINISH					
NEXT ASSY	USED ON						
APPLICATION		DO NOT SCALE DRAWING					
				SIZE	DWG. NO.	REV	
				B	P004-01	A	
				SCALE: 1:1 WEIGHT:		SHEET 1 OF 1	

4

3

2

1

4

3

2

1

B

B

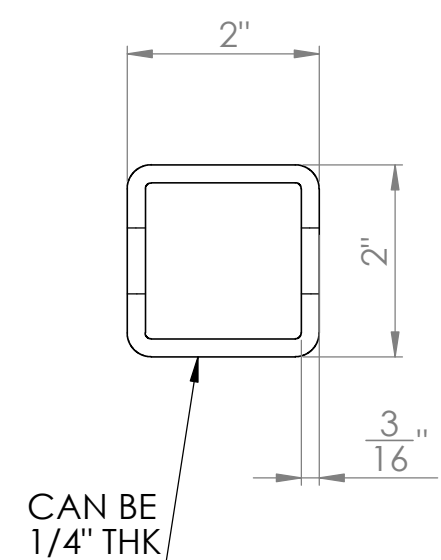
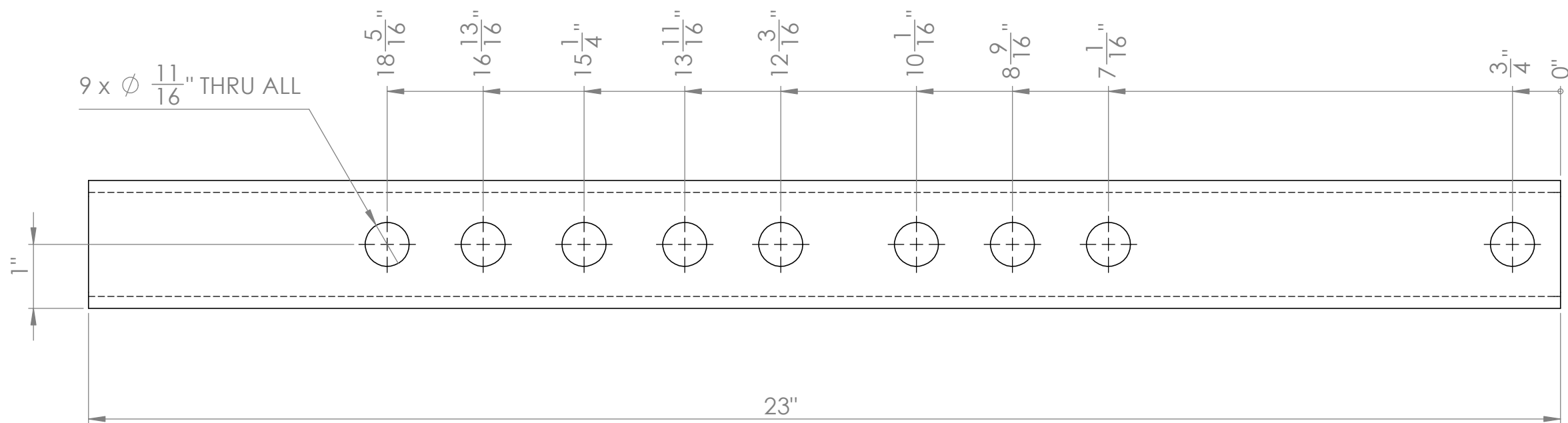

QTY 2

A

A

PROPRIETARY AND CONFIDENTIAL
 THE INFORMATION CONTAINED IN THIS DRAWING IS THE SOLE PROPERTY OF <INSERT COMPANY NAME HERE>. ANY REPRODUCTION IN PART OR AS A WHOLE WITHOUT THE WRITTEN PERMISSION OF <INSERT COMPANY NAME HERE> IS PROHIBITED.

		UNLESS OTHERWISE SPECIFIED:		NAME	DATE	Kamloops Waterski Club	
		DIMENSIONS ARE IN INCHES		DRAWN	PD	TITLE: TOP ADJUSTMENT TUBE	
		TOLERANCES:		CHECKED			
		FRACTIONAL \pm		ENG APPR.			
		ANGULAR: MACH \pm BEND \pm		MFG APPR.			
		TWO PLACE DECIMAL \pm		Q.A.			
		THREE PLACE DECIMAL \pm		COMMENTS:			
		INTERPRET GEOMETRIC TOLERANCING PER:					
		MATERIAL					
NEXT ASSY	USED ON	FINISH					
APPLICATION		DO NOT SCALE DRAWING					
SIZE	DWG. NO.	REV					
B	P005-01	A					
SCALE: 1:2		WEIGHT:		SHEET 1 OF 1			

4

3

2

1